

HIJECTORS -- VENTURI MIXERS FOR HIGH PRESSURE GASES

MODEL: 2201-H, 2202-HC

Revision: 0

BULLETIN
2201, 2202

HIJECTOR COMPLETE WITH VALVE AND GAUGE

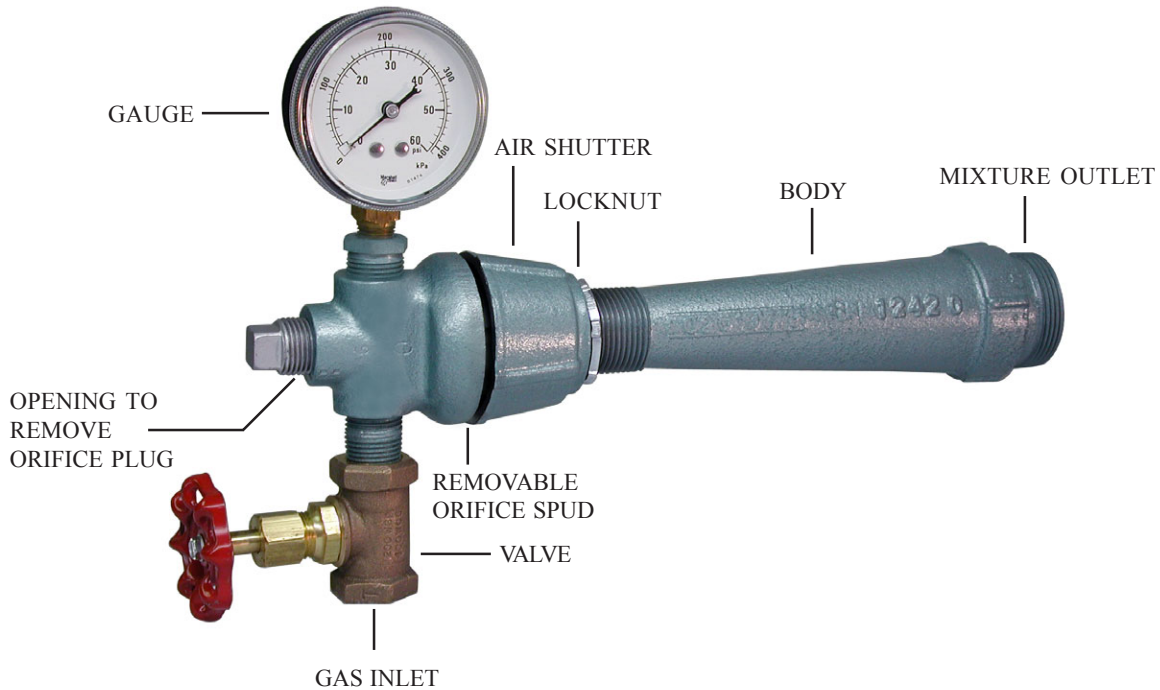

GENERAL DESCRIPTION

Hijectors are designed to use high pressure gas (up to 35 psig) to entrain all the air needed to make a complete combustible mixture and to deliver it to the burners at the highest possible pressure.

Hijectors are designed along thoroughly proved lines but the external arrangement of the parts has been changed to permit incorporating a number of refinements. These refinements are of particular advantage to the installation and maintenance engineer. By reversing the usual operation of the air shutter and locating it on the body, the following advantages develop:

- (a) Orifice spud may be removed easily without disconnecting piping.
- (b) Overall length of unit is materially cut down.
- (c) Orifice and air entrainment space easily accessible for cleaning or inspection.
- (d) Air entrainment noises reduced.
- (e) Shutter cannot get lost even though backed entirely out of the way.

A mounting boss with tapped holes simplifies mounting the Hijector solidly on a furnace or appliance.

APPLICATION

To secure the best all around operation when using high pressure gas, it is necessary that the relation between burner area and orifice area be correct and that the right sized Hijector be used. Also, piping between Hijector and burners should be large enough and straight enough to prevent undue loss of mixture pressure. See next two pages for complete selection data.

Where high pressure gas is available, Hijectors eliminate the requirement of air blowers or pressure air for combustion jobs, and are simple to install, inexpensive to use and easy to operate.

CAUTION: Operation of combustion equipment can be hazardous resulting in bodily injury or equipment damage. Each burner should be supervised by a combustion safeguard and only qualified personnel should install, make system adjustments and perform any required service.



pyronics inc.

COMBUSTION FOR INDUSTRY

17700 MILES ROAD
CLEVELAND, OH 44128
www.pyronics.com

Tel: 216-662-8800
Fax: 216-663-8954
marketing@pyronics.com

NOTICE: PYRONICS practices a policy of continuous improvement in the design of its products. It reserves the right to change the specifications at any time without prior notice.

HIJECTORS -- VENTURI MIXERS FOR HIGH PRESSURE GASES

BULLETIN
2201, 2202
PAGE NO.2

HIJECTOR CAPACITY TABLE - MANUFACTURED AND MIXED GASES

Kind of Gas Average BTU	Coke Oven Gas 500 - 550		Carb. Water Gas 500 - 550		Mixed Nat. - Mfd. Gas 750 - 850	
Specific Gravity	0.42		0.55		0.60	
Air/Gas Ratio	4.7/1		4.5/1		7.5/1	
Gas Pressure	10 psig		10 psig		15 psig	
Mixture Pressure	3.4" W.C.		3 - 4" W.C.		2.1" W.C.	
Gas Capacity CFH	Catalog Number	Approx. Burner Area * Sq. In.	Catalog Number	Approx. Burner Area * Sq. In.	Catalog Number	Approx. Burner Area * Sq. In.
40	6H-65	0.080	6H-63	0.070	6H-66	0.129
60	6H-61	0.100	6H-56	0.110	6H-57	0.218
80	6H-56	0.141	6H-54	0.155	8H-55	0.318
100	8H-54	0.198	6H-53	0.181	8H-54	0.357
125	8H-52	0.263	8H-51	0.229	10H-53	0.417
150	8H-50	0.320	8H-49	0.273	10H-51	0.530
175	10H-48	0.377	8H-47	0.315	12H-49	0.629
200	10H-46	0.427	10H-44	0.377	12H-5/64	0.719
250	10H-42	0.570	10H-41	0.471	12H-44	0.870
300	12H-40	0.626	10H-37	0.552	16H-3/32	1.040
350	12H-37	0.705	12H-34	0.628	16H-38	1.220
400	12H-34	0.804	12H-31	0.735	20H-7/64	1.410
450	16H-32	0.877	12H-30	0.844	20H-33	1.500
500	16H-1/8	1.020	16H-29	0.945	20H-31	1.700
550	16H-29	1.210	16H-28	1.010	20H-30	1.940
600	16H-28	1.290	16H-26	1.110	24H-29	2.180
650	20H-26	1.410	16H-24	1.180	24H-28	2.330
700	20H-24	1.510	16H-21	1.290	24H-27	2.440
750	20H-5/32	1.590	20H-19	1.400	24H-25	2.630
800	20H-21	1.660	20H-18	1.470	24H-23	2.800
850	20H-19	1.800	20H-17	1.530	32H-21	2.980
900	20H-18	1.870	20H-15	1.660	32H-19	3.240
950	24H-17	1.950	20H-13	1.750	32H-18	3.380
1000	24H-16	2.040	20H-12	1.830	32H-17	3.520
1100	24H-13	2.230	20H- 8	2.020	32H-15	3.820
1200	24H-10	2.440	24H- 5	2.160	32H-12	4.210
1300	24H- 7	2.650	24H- 3	2.360	32H- 9	4.520
1400	24H- 5	2.750	24H- 1	2.650	32H- 6	4.900
1500	32H- 3	2.950	24H-15/64	2.800		
1600	32H- 2	3.180	24H-B	2.950		
1800	32H-15/64	3.580	32H-1/4	3.190		
2000	32H-1/4	3.990	32H-G	3.480		
2200	32H-17/64	4.600	32H-J	3.900		
2400	32H-9/32	5.150	32H-9/32	4.040		
2600			32H-19/64	4.500		
2800			32H-5/16	5.000		

HIJECTORS -- VENTURI MIXERS FOR HIGH PRESSURE GASES

BULLETIN
2201, 2202
PAGE NO.3

HIJECTOR CAPACITY TABLE - NATURAL GAS AND PROPANE

Kind of Gas Average BTU	Natural Gas 950 - 1200		Propane 2500		BURNER AREA DATA
Specific Gravity	0.65		1.52		
Air/Gas Ratio	10/1		24/1		
Gas Pressure	25 psig		25 psig		
Mixture Pressure	1.8" W.C.		0.8" W.C.		
Gas Capacity CFH	Catalog Number	Approx. Burner Area * Sq. In.	Catalog Number	Approx. Burner Area * Sq. In.	
10	6H-78	0.050	6H-76	0.202	* Burner areas shown in capacity tables are based on discharge coefficient of 100%. These areas should be multiplied by one of the following factors according to the type of burner used with the Hijector.
15	6H-76	0.080	6H-73	0.293	
20	6H-74	0.103	8H-70	0.404	
30	6H-70	0.159	8H-66	0.560	
40	6H-68	0.195	10H-61	0.780	
50	8H-64	0.262	12H-57	0.943	
60	8H-61	0.308	12H-3/64	1.130	
70	8H-59	0.338	16H-55	1.380	
80	10H-57	0.372	16H-54	1.550	
90	10H-3/64	0.443	16H-53	1.810	
100	10H-55	0.543	16H-1/16	2.000	Flame Retaining or Piloted Burners and Blast Tips. Also Pepper Box type tunnel burners. Factor = 1.3
120	10H-54	0.610	20H-51	2.290	
140	12H-53	0.712	20H-50	2.500	
160	12H-52	0.813	20H-5/64	3.120	
180	12H-51	0.905	24H-45	3.440	
200	16H-50	0.986	24H-44	3.780	Annular or single port type, round or flat nose tunnel burners. Factor = 1.3
220	16H-49	1.080	24H-43	4.050	
240	16H-5/64	1.230	32H-41	4.710	
260	16H-46	1.320	32H-39	5.060	
280	16H-45	1.350	32H-38	5.260	
300	20H-44	1.490	32H-36	5.790	
320	20H-43	1.590	32H-35	6.170	
340	20H-42	1.760	32H-33	6.510	
360	20H-41	1.860	32H-32	6.880	
380	20H-40	1.930	32H-31	7.350	
400	20H-39	2.000			Venturi type steel tunnel burners. Factor = 0.8
450	24H-36	2.280			
500	24H-34	2.480			
550	24H-32	2.710			
600	24H-31	2.900			
650	32H-1/8	3.150			
700	32H-30	3.320			
750	32H-29	3.720			
800	32H-9/64	3.980			
850	32H-27	4.170			
900	32H-25	4.500			
950	32H-23	4.770			
1000	32H-22	4.970			
1050	32H-20	5.220			

HIJECTOR CAPACITY MULTIPLIER TABLE

Gas Press. Listed	For pressures other than listed							
	5#	10#	15#	20#	25#	30#	35#	40#
10#	0.709	1.000	1.220	1.410	1.58	1.73	1.87	2.00
15#	0.578	0.815	1.000	1.150	1.29	1.41	1.53	1.63
25#	0.447	0.631	0.775	0.895	1.00	1.09	1.18	1.26

CAUTION: Operation of combustion equipment can be hazardous resulting in bodily injury or equipment damage. Each burner should be supervised by a combustion safeguard and only qualified personnel should install, make system adjustments and perform any required service.



pyronics inc.

COMBUSTION FOR INDUSTRY
17700 MILES ROAD
CLEVELAND, OH 44128
www.pyronics.com

Tel: 216-662-8800
Fax: 216-663-8954
marketing@pyronics.com

NOTICE: PYRONICS practices a policy of continuous improvement in the design of its products. It reserves the right to change the specifications at any time without prior notice.

HIJECTORS -- VENTURI MIXERS FOR HIGH PRESSURE GASES

BULLETIN
2201, 2202
PAGE NO.4

DIMENSIONS

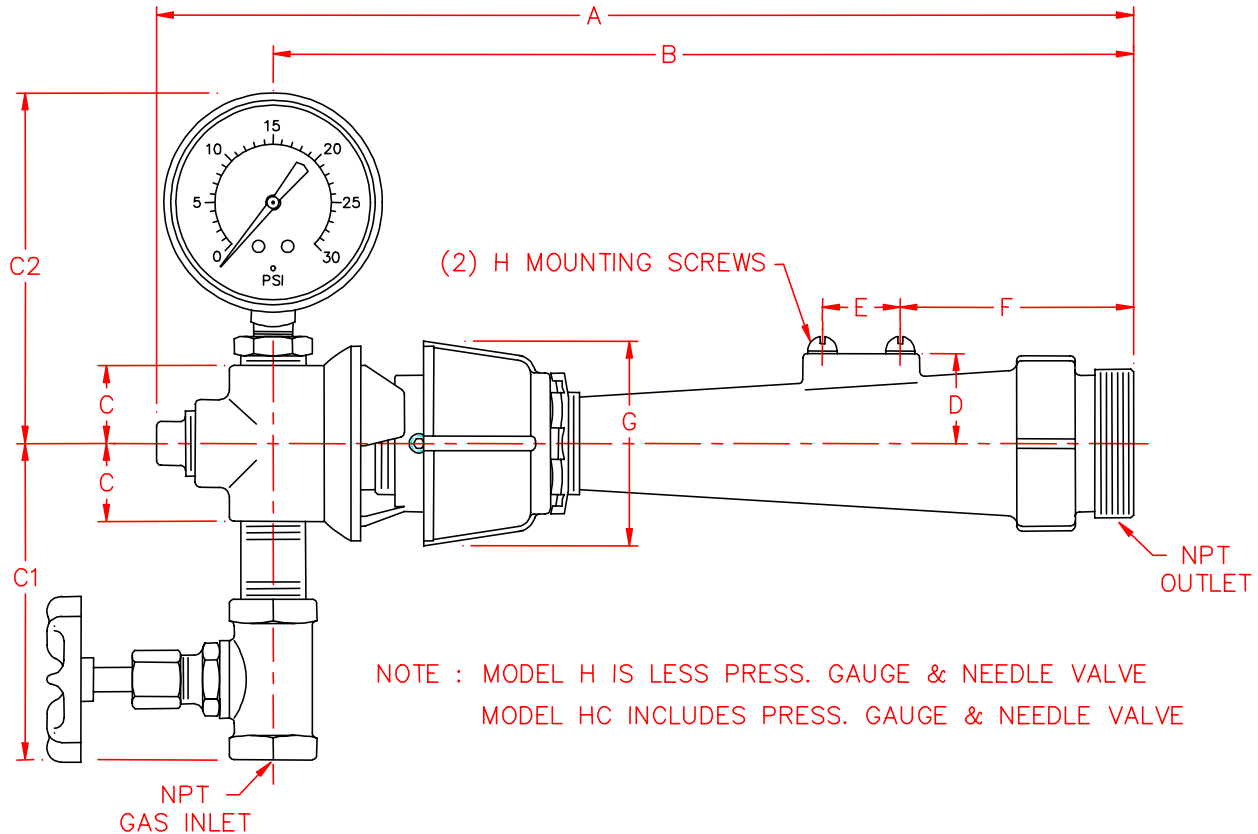

CATALOG NUMBERS		Outlet Pipe Size NPT	Inlet Pipe Size NPT	A	B	C	C1	C2	D	E	F	G	H	Approx. Weight Without NV and Press. Gauge Lbs.
With NV and Press. Gauge	Without NV and Press. Gauge													
6HC	6H	3/4	3/8	7-1/4	6	13/16	3-7/16	4-1/4	-----	-----	-----	2-3/8	-----	2.5
8HC	8H	1	3/8	9-1/16	7-13/16	13/16	3-7/16	4-1/4	7/8	1	2-1/8	2-3/8	1/4"-20	3.5
10HC	10H	1-1/4	1/2	11-9/16	10-1/16	1	4-1/16	4-1/2	1-1/8	1	2-3/4	2-5/8	1/4"-20	5.0
12HC	12H	1-1/2	1/2	12-9/16	11-1/16	1	4-1/16	4-1/2	1-3/16	1	3	2-5/8	1/4"-20	6.0
16HC	16H	2	3/4	16-3/8	14-7/16	1-3/8	4-3/4	5	1-1/2	1	3-1/4	3-5/8	1/4"-20	12.0
20HC	20H	2-1/2	3/4	19-5/16	17-3/8	1-3/8	4-3/4	5	1-13/16	1	3-5/8	3-5/8	1/4"-20	17.0
24HC	24H	3	1	23-7/16	21-5/16	1-1/2	5-3/4	5-3/16	2-1/16	1-1/2	4-3/4	4-1/4	3/8"-16	22.0
32HC	32H	4	1-1/4	29-1/2	27	1-3/4	6-5/8	5-7/16	2-5/8	1-1/2	5-1/2	5-3/8	3/8"-16	40.0

Note: All dimensions are in inches. NV = Needle Valve.

ORDERING INFORMATION

Please include the following information for each size Hijector ordered:

1. Number required.
2. Catalog number complete, showing whether type H or HC and orifice size.
3. Specify gauge range or maximum gas pressure used. 30GP is standard.
4. List additional parts required by catalog number.
5. Shipping Instructions.

If in doubt about Hijector selection, send complete information about burner, gas and application so we may assist you.

The content on or accessible through CombustionDepot.com, (including, but not limited to) text, graphics and other materials, are provided by CombustionDepot.com, for informational purposes only. CombustionDepot.com does not claim ownership to any of the photos, images, or pictures of products on the site. These depictions are solely for information purposes and may not be an exact replication of the related product available for sale. All PDF and specification pages are gathered from the OEM web sites or publicly available information. CombustionDepot.com does not claim responsibility for any of the information found on these bulletins, documents, literature, specification charts, etc. and such information is subject to change without notice.