

SEAL BEARING ASSEMBLY | INSTALLATION AND OPERATING INSTRUCTIONS

File No: 10.833
Date: SEPTEMBER 11, 2020
Supersedes: 10.833
Date: DECEMBER 12, 2013

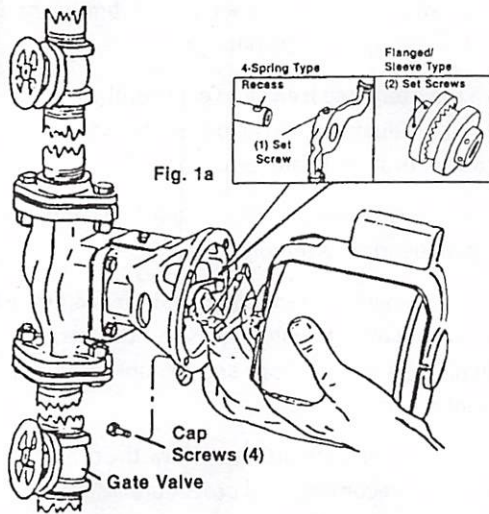

FIG 1. Removing motor assembly

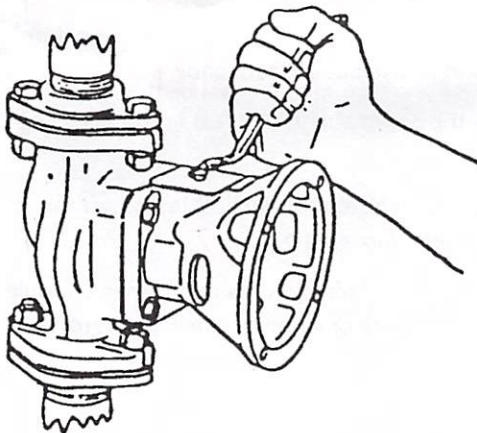

FIG 2. Removing bearing assembly

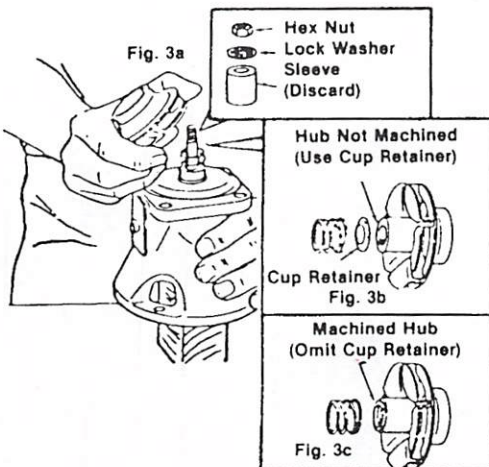

FIG 3. Installing impeller on new bearing assembly

REPLACEMENT OF SEAL BEARING ASSEMBLY (WITH OR WITHOUT IMPELLER KIT)

- 1 Shut off electric power supply to pump. Drain system (or close gate valves if available).
- 2A Loosen set screw holding 4-spring coupler to shaft of bearing assembly. Loosen enough so that set screw clears recess in shaft (FIG. 1A). If flanged/sleeve type coupler is used, step 2A is not necessary until after step 2B.
- 2B Remove motor assembly (and attached coupler) by removing 4 cap screws. See FIG. 1.
- 3 Remove bearing assembly from pump body by removing body cap screws (FIG. 2).

IF REPLACING THE SEAL BEARING ASSEMBLY WITH IMPELLER KIT, SKIP TO STEP #6.

- 4 Remove and clean Impeller from old bearing assembly.
 - 5 Position new bearing assembly on a wood block (FIG. 3) to force shaft upward while installing Impeller. Then install impeller as follows:
 - A. Remove hex nut and lockwasher (cap nut and ring washer on bronze assemblies) and discard plastic sleeve (FIG. 3A).
 - B. Determine if cup retainer is needed. If hub of impeller is not machined (FIG. 3B), use cup retainer. If hub of impeller is machined (FIG. 3C), then discard cup retainer.
 - C. Assemble Impeller to shaft, using lockwasher and hex nut (or ring washer and cap nut on bronze assemblies). tighten nut securely.
 - 6 Remove and discard old gasket. Clean off area in pump body (FIG. 4).
 - 7 With new gasket in place, fit Seal Bearing Assembly / Impeller kit into pump body and tighten body cap screws (FIG. 5).
- IMPORTANT:** Gap between bearing assembly and pump body is normal when using an Armstrong bearing assembly with any circulator; do not overtighten body cap screws.
- 8 Connect coupler to shaft of bearing assembly by placing thumb of one hand behind coupler-half to be attached and sliding it onto shaft, using care to line up set screw with

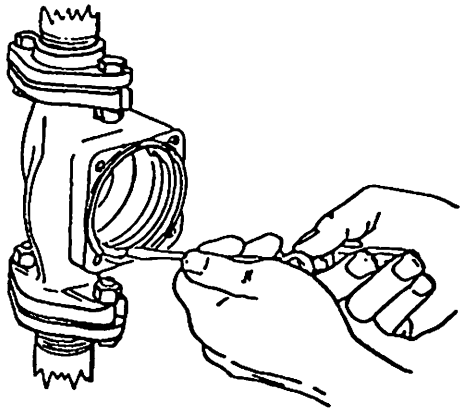

FIG 4. Cleaning off gasket area

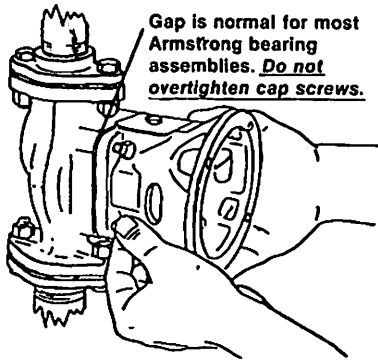

FIG 5. Installing bearing assembly to body

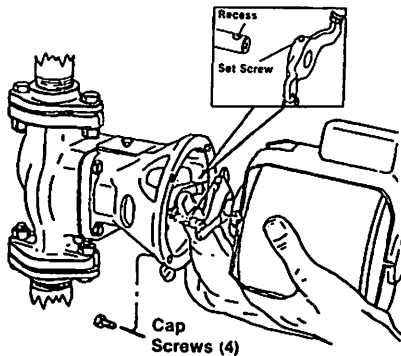

FIG 6. Replacing motor assembly

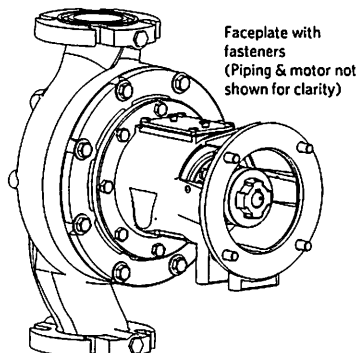

FIG 7A. SBA 6 series with Face plate

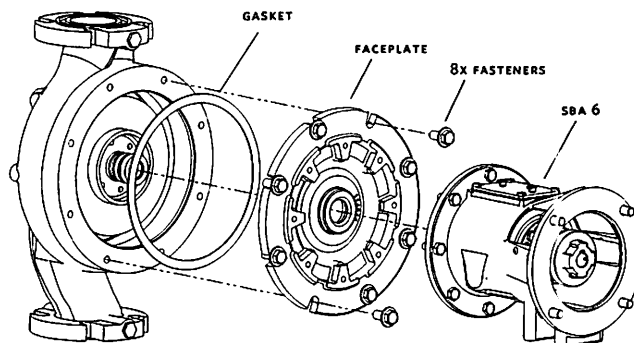

FIG 7B. SBA 6 series with Face plate details (exploded view)

recess in shaft. Securely tighten set screw in recess and attach motor assembly to bearing assembly with 4 cap screws. In case of couplers with 2 set screws, tighten one in recess and one snug on shaft (FIG. 5).

- 9 If you have a **maintenance free SBA** (part number contains MF or product labelled as **DOES NOT NEED ANY OILING OR GREASING**) go to step #10.

Add complete contents of oil bottle (or bottles) supplied to the oil cup on bearing assembly.

This motor has been lubricated properly at the factory. At the start of each following heating season, however, on motors with oil cups, add 15 drops SAE 30 non-detergent oil to each motor cup.

If motor is fitted with grease fittings, follow the motor manufacturer's recommended procedure. Motors without oil cups or grease fittings are custom-greased for several years operation and require little or no attention.

- 10 Pump must be fully primed before start-up. Fill system piping and pump body and vent complete system, turning pump by hand to dislodge air from body.
- 11 Restore electric power supply and test for proper operation.
- 12 Follow the remaining steps as applicable from #1 thru #11 to change 6 series SBA (FIG 7A).
- 13 Face plate along with fasteners has to be removed while replacing the SBA with or without impeller kit (FIG 7B).

TORONTO

23 BERTRAND AVENUE
TORONTO, ONTARIO
CANADA, M1L 2P3
+1 416 755 2291

BUFFALO

93 EAST AVENUE
NORTH TONAWANDA, NEW YORK
U.S.A., 14120-6594
+1 716 693 8813

BIRMINGHAM

HEYWOOD WHARF, MUCKLOW HILL
HALESOWEN, WEST MIDLANDS
UNITED KINGDOM, B62 8DJ
+44 (0) 8444 145 145

MANCHESTER

WOLVERTON STREET
MANCHESTER
UNITED KINGDOM, M11 2ET
+44 (0) 8444 145 145

BANGALORE

#59, FIRST FLOOR, 3RD MAIN
MARGOSA ROAD, MALLESWARAM
BANGALORE, INDIA, 560 003
+91 (0) 80 4906 3555

SHANGHAI

UNIT 903, 888 NORTH SICHUAN RD.
HONGKOU DISTRICT, SHANGHAI
CHINA, 200085
+86 (0) 21 5237 0909

SÃO PAULO

RUA JOSÉ SEMIÃO RODRIGUES AGOSTINHO,
1370 GALPÃO 6 EMBU DAS ARTES
SAO PAULO, BRAZIL
+55 11 4785 1330

LYON

93 RUE DE LA VILLETTE
LYON, 69003 FRANCE
+33 (0) 420 102 625

DUBAI

JAFZA VIEW 19, OFFICE 402
P.O. BOX 18226 JAFZA,
DUBAI - UNITED ARAB EMIRATES
+971 4 887 6775

MANNHEIM

DYNAMOSTRASSE 13
68165 MANNHEIM
GERMANY
+49 (0) 621 3999 9858

